

Power Protection for
Business Critical Continuity

Series 7400 M (10/20/30/40/60 kVA)

Maximum Protection For Mission Critical Network Applications



*Compact Three-phase UPS with
Optimum Load Performance And
Battery Management System*

Power Quality Solutions

Series 7400 M

Hi-Availability UPS



Input Total
Current Harmonics



Input Power
Factor

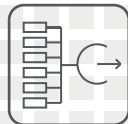

Expandable up to
Six UPS modules

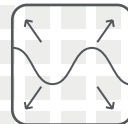

Wide Input Voltage
& frequency Ranges

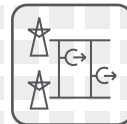

Multi Bus
Compatible

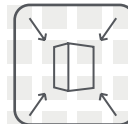

Compact
Footprint

 **Liebert**[®]

EMERSON[™]
Network Power

Series 7400 M

Compact 3-phase UPS With Optimum Load Performance And Battery Management System

Today's electrical network cannot provide High Nine power quality. Many problems like voltage / frequency fluctuations, harmonics, transients, blackouts, brownouts are still present. They may cause your critical and sensitive systems to fail with negative impact on your business.

The Liebert series 7400 M addresses all the power quality needs of today's networked economy by providing a perfect sinewave output voltage with stable frequency, over and above offering many other important customer values.

Benefits

- On-line double conversion UPS: makes your load independent from both main's voltage and frequency. Ensures server-grade high quality of power.
- IGBT technology PWM inverter switching technology: provides your load with perfect sinewave voltage.
- High efficiency performances: lower cost of ownership.
- Excellent performances with either 100% unbalanced and 100% non-linear loads with crest factor up to 3:1 without derating: no need to care about the distribution of your single phase loads between output phases nor to oversize the UPS.
- Super-servers, mini-computers and multi-processing systems.
- Advanced battery management systems with programmable battery testing: constantly monitors the health of the battery pack keeping the battery ready to work for emergency situations.
- Small footprint and convenient maintenance access: ease of positioning and saving of floor-space.
- Inverter with high overload capability: no need to oversize UPS; reduced Initial Investment.
- Inverter Output protected against short circuit: high protection to the inverter hence more availability of the systems; Investment Protection.
- Zero footprint for optional tuned filter for the input: lower cost of ownership because of space saving and reduced electricity bill.
- Output kW without deration up to 0.9 lead power factor.

Major Applications

- Information Technology Servers (LAN, WAN, e-mail, ERP, Web Digital Archives, IntraNet) Networking (Routers, Hubs, Switches, Multiplexer, Bundler, Unbundler, Modems)
- Banks, Insurance and, Financial Services
- Telecommunications, Billing Computers
- Medical Diagnostics, MRI, CT Scan, Cath Lab
- Process Automation, Small processes, Light Robotics



Series 7400M An Outstanding Performer

The system's advanced true-online, double conversion topology features a Micro-processor based controlled, IGBT Inverter.

Rectifier

The rectifier provides up to 0.99 Input Power Factor (PF), up to 3% of Input Current Total Harmonic Distortion (THDi) with Optional configurations of Harmonic filters and the widest input voltage window and frequency tolerances.

PWM Based IGBT Inverter

Advanced inverter control technology provides the highest output power quality, ensuring very low output voltage THD and superior waveform to protect connected loads.

It operates under a wide variety of conditions, handling 100% non-linear loads with 3:1 crest factor, as well as 100% unbalanced loading.

The inverter control enables 7400M to be suitable for the widest ranges of loads required by the market; delivering full active power rated kW up to 0.9 leading PF loads.

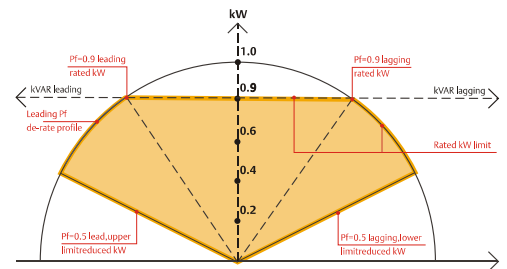

Selected Power Options

Input Isolation Transformer

- Compatible with Liebert AF, the Active Harmonic Filter
- Wide range of solutions specially designed for handling current harmonic on bypass at different stages
- Available for rectifier and / or bypass supply

Protection Degree (IP) For 7400M Enclosure

- To address stressed environmental conditions, UPS with higher than IP20 degree of protection can be made available for most of the kVA ratings of 7400M

DC Ground Fault Indication

- This provides indication of occurrence of battery ground fault problems

i-Enersave Module

- Purpose of this logic is to optimally load each UPS system in a multi UPS parallel system so that each UPS works in its most efficient band of operation while total installation being subjected partial load. This logic keeps minimum number of UPS system in Operation as per load demand. The choice of redundancy level is settable in the logic to have high up-time depending on criticality index of load, it has wide use in industries where load pattern is highly dynamic.
- Auto Sleep and Auto sequencing options available with this logic ensures no UPS System is spared from regular health check up, if prolonged conditions persist. Thus enhanced efficiency of overall system reduces Energy cost and increased customer profitability.

This tacitly reduce consumption of natural resources, combustion of fossil fuel, hence reduction in green house gas emission and carbon footprint.

Power Walk-in for 1+N System

- The module power walk-in is standard. This option can be for the module restart delay after the mains return. This is very useful for applications with motor generator at the input

LBS

- This ensures the synchronisation of outputs of two Independent UPS systems to form Dual Bus Architecture for High availability of Critical Bus

Liebert LTS, Static Transfer Switch

- This allows critical load to be transferred between two independent, synchronised AC power sources without any risk of load disturbances
- This allows automatic transfer of load between the two sources

TVSS

- This is a Transient Voltage Surge Suppressor
- This offers protection from damaging transients and electrical line noises
- This is normally connected at the I/P and O/P path of 7400M as an optional item

Advance Monitoring & Communication Capabilities Keep You In Control

Power Communication Options

When choosing the best system to protect your mission critical applications, an important consideration would be the software and communication options. As part of our commitment to provide the best solution for you, we offer a wide range of sophisticated software and communication options for 7400M.

Communications Options

■ OpenComms™ Web Card

- to meet the needs of network managers by providing interface to network management systems through SNMP/HTTP Protocols and Control through Building Management Systems Via Modbus and Jbus Protocols.

■ Relay Contact Card

- addresses the basic monitoring and communications needs of users/maintenance personnel.

■ Other Remote Communications

The Liebert 7400M provides other communications alternatives through RS-232 & RS-485 ports.

In addition to remote communications, service personnel can also use the RS-232 port for local downloading of data, while the RS-485 port can be utilized for a variety remote communications application.

Software Solutions

- Liebert UPS Monitoring Software.
- Facilitywide monitoring (SiteScan).
- Shutdown software for your computer equipment : MultiLink™ Automated System.
- Simultaneous monitoring via different protocols.
- Emerson Power Quality Monitoring solutions.
- Wall mounted RAM (Remote Alarm Monitor) Panel.

Local Communications

Liebert 7400M provides excellent local communications through its LED-based mimic diagram and LCD panel.

While the mimic shows the live power path, the back-lit contrast-adjusting LCD provides you with detailed data on the unit and the system in twelve different languages through a user-friendly menu.

Liebert Power Monitoring Capabilities:

- MultiLink™ Automated System Shutdown Software
- OpenComms™ Nform Monitoring System
- SiteScan™ Web Comprehensive
- Remote Alarm Monitoring Panel
- Third-Party Monitoring Systems



7400M can be scaled up to as high as 6 modules using any of the following configurations to achieve either scalability or redundancy of desired percentage

- 1+N configuration without any kind of centralised static switch
- Some more configurations are explained further in this brochure
- For other configurations, please contact our nearest sales office / representative

■ 1+N Configuration with Distributed bypass System

- Up to six modules in parallel
- Increase the system reliability
- Increase the availability of quality power following the load demand even if it was not forecasted or planned at the beginning of the project: ease of techno economic Expandability
- Increase the maintainability
- The total load is less than or equal to the rating of the single UPS (depending on the desired redundancy level) and is shared between all modules

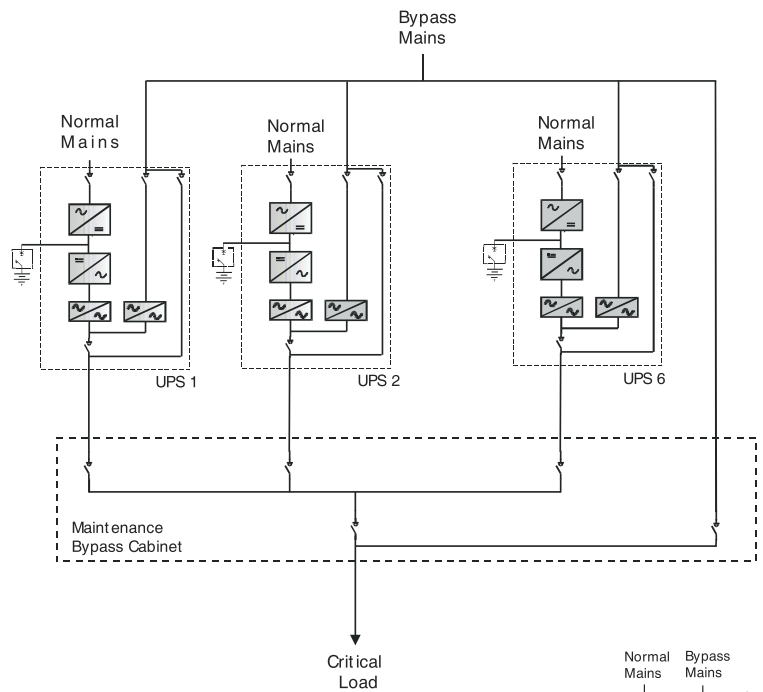

■ Hot Stand-by Configuration

- Feed one (Priority) or two (Priority and Normal) load banks depending on the application need
- Increase the reliability of the priority load
- Increase the maintainability
- Easy connection
- Can be implemented in the existing
- Installation regardless of the UPS size, the generation of (device or technology or philosophy of control) and the manufacturer

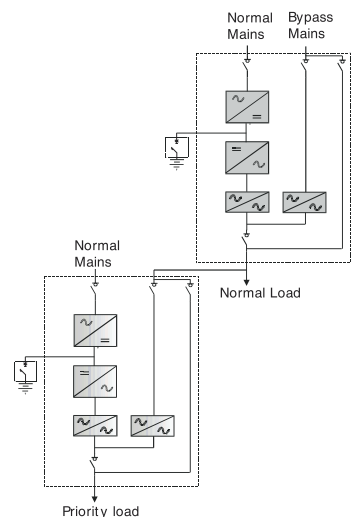

■ Dual Bus System with Liebert LTS, STS2 or Hiswitch2

- Provide supply to the loads from two independent power sources
- The two may be different in terms of power rating and redundancy
- The two BUS outputs are in synchronism between them
- Automatic transfer of the load between the two sources in case of fault using Liebert LTS
- Increase dramatically the maintainability and reliability

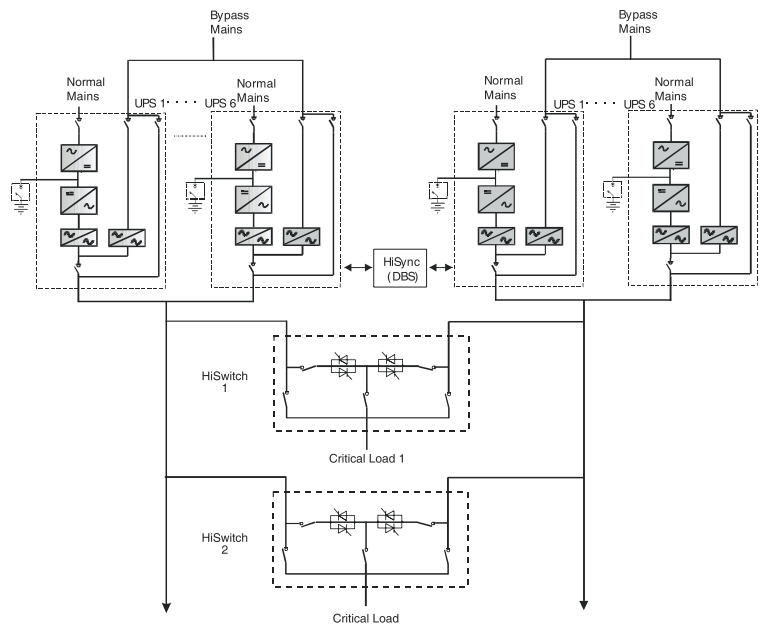

■ Multimodule Configuration WITH Centralised Bypass Called Main Static Switch (MSS)

- Up to six Modules in parallel
- Increase the system reliability
- Increase the power availability up to the MSS Capacity
- Increase the maintainability
- The Total load is less than or equal to the rating of the single UPS (depending on the desired redundancy level). The load is shared between all modules.

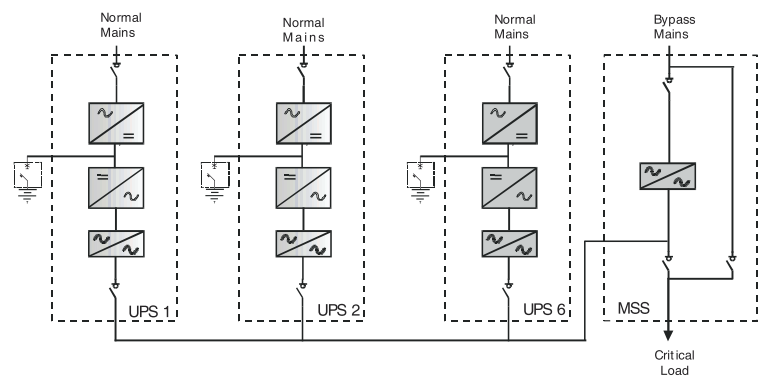

General Features

7400M UPS System					
Normal Rating [kVA]	10	20	30	40	60
(0.8 pf)/kW***	8kW	16kW	24kW	32kW	48kW
Environment					
Noise	56dBA				
Temperature	Operating Temperature: 0 to 40°C **; Storage Temperature: -25 to 70°C				
Humidity	<90% at 20° C				
Altitude	<1000m (derate by 1% per 100m between 1000 and 2000)				
Physical Characteristics					
Depth [mm]	800				
Width [mm]	710				
Height [mm]	1400				
Weight [kgs]	400	430	480	540	620
Ingress Protection Class	Degree of Protection: IP 20 (IP: 31 On Request)				
Color	RAL 7021				
Input					
Rectifier Type	6 pulse (Also available with 12 pulse)				
Voltage	380/400/415V (+15/-15%) -3Ph - 3w				
Frequency	50 or 60 Hz +/-10%				
I/PTHDi	Up to 3% *				
Power Factor	Up to 0.99 *				
Bypass					
Voltage	380/400/415V (+10/-10%) -3Ph - 4w				
Frequency	50 or 60 Hz +/-5%				
DC Intermediate circuit					
DC Ripple	<=1% w/o Battery Connected				
DC Nominal Voltage	384V/396V/408V				
Types of Batteries	Ni-Cd / Wet-Acid / VRLA / SMF				
Output					
Voltage	380/400/415V - 3Ph - 4w				
Voltage Stability					
- Steady State	+/-1%				
- 100% Load Step	+/- 5%				
Power Factor	0.9 lag to 0.9 lead w/o De-ration				
Frequency	50 or 60Hz				
Frequency Stability					
- Synchronised with the bypass supply	+/- 1%				
- Auto-Synchronised	+/- 0.1%				
Overall Efficiency AC/AC - 3 Ph					
Up to 93% †					
Overload capacity from inverter at nominal voltage					
- 3 Ph	110% for 60 minutes, 125% for 10 minutes, 150% for 1 minute				
- 1 Ph	200% for 30 seconds				
Short circuit current from inverter					
- 3 Ph	1.5 In for 5 seconds (in accordance with EN 50091-1-1)				
- 1 Ph	2.2 In for 5 seconds				
Voltage Distortion with Linear Load	<1%				
Voltage Distortion with 100% Non-Linear Load	<3% Ph / Ph, <5% Ph / N (distorted load as per EN50091 - 3)				
Max. Deliverable Power					
With Non-Linear Load (CF = 3:1)	100%				
Max Unbalanced Load	100%				
Voltage Displacement with 100% Unbalanced Load	120 +/- 1° el				
Output Voltage Dissymetry With 100% Unbalanced Load	2%				
Communication					
SNMP/HTTP, Rs-485//MODBUS, SiteScan, Nform, Multilink S/W					

* Optional with various configuration of harmonic filters

Depending on Configuration

** Ratings also available @ 50°C

** Operating Temperature @ 25°C System can deliver more Power than Nominal.

*** Also available with 0.9 power factor

Country Office

Emerson Network Power (India) Private Ltd.
Plot No. C-20, Road No. 19, Wagle Estate,
Thane (W), Maharashtra - 400 604. India.

Tel.: 91-22-33154400

Fax: 91-22-25828358

Toll Free No 18002096070

Email: marketing.india@emerson.com

FROST & SULLIVAN

Voice of Customers UPS Awards 2004-05 for Product Line
& Customer Service Awards in IT, Telecom,
Large Enterprise & Hospitals and
Customer Service Leadership Award in BFSI



Best IT Hardware Company
Maharashtra IT Award 2006-07



Emerson Among Top 50
On Fortune Survey Of
"Worlds Most Admired"
Companies.



www.emersonnetworkpower.co.in

Emerson Network Power.

The global leader in enabling Business-Critical Continuity™.

- AC Power
- Embedded Computing
- Outside Plant
- Racks & Integrated Cabinets
- Connectivity
- Embedded Power
- Power Switching & Controls
- Services
- DC Power
- Monitoring
- Precision Cooling
- Surge Protection

While every precaution has been taken to ensure accuracy and completeness in this brochure, Emerson Network Power assumes no responsibility, and disclaims all liability for damages resulting from use of this information or for any errors or omissions.

For disposal of Batteries Please visit the below link:
<http://www.cpcb.nic.in/divisionsofheadoffice/hwmd/lead.pdf>

Note: Specifications & Features may vary based on the condition.

Emerson Network Power and the Emerson Network Power logo are trademarks and service marks of Emerson Electric Co. © 2009 Emerson Electric Co.